

## The PSX-1,2,3,4 Series

Intelligent, DCC, Solid State Circuit Breakers  
Integrated Block Detection and Feed Back

Manual Rev M 4/15  
Software Rev K 4/15

Not for DC, Analog Use

**Quick Start: see Pg-10, Test Before Installing  
see Pg 10. All Programming is Optional!**

Designed by Larry Maier ★ Developed by DCC Specialties ★ US Patent 7,810,435

**New Exclusive Digitrax Configuration Jumper, see Pg-3**

The PSX series includes 4, DCC Power District Circuit Breakers that incorporate a solid state design, block detection and network feedback.

PSX-1: 1 Block Control    PSX-3: 3 Block Control  
PSX-2: 2 Block Control    PSX-4: 4 Block Control



There are (4) versions of the new PSX-AR Series:  
Integrated DCC Circuit Breaker, Auto-Reverser, Stationary Decoder

- (1) PSX-AR, w/ integrated Stall Motor Decoder
- (2) PSX-ARFB, same as above has added network Feed Back
- (3) PSX-ARSC, w/ integrated Snap Coil Decoder
- (4) PSX-ARSCFB, same as above has added network FeedBack.

*The Power Shield X series is a product of years of research into problems dealing with false overloads that cause premature shut down of DCC Boosters and other Circuit Breakers. These false overloads are caused by large capacitors used in sound systems decoders or lighted passenger cars. The overload appears as a short circuit until the capacitors are charged. The logic on the new Power Shield X Series determines if the load is a true short or just an overload due to discharged capacitor.*

### Versions Available:

PSX-1 One Output, PSX-2 Two Outputs, PSX-3 Three Outputs, PSX-4 Four Outputs:

**All Solid State Operation:** Fast, solid state design with reliable quiet action....no clicks or sparks.

**Adaptive Load Reset:** Electronically determines if the overload is a real short or due to excess capacitance in sound decoders or lighted passenger cars.

**Boost for Low Power Systems:** Some low power DCC Systems boosters need a boost when resetting. Adding this jumper helps reset low power output systems.

**Auto Stop with CV Reset:** A photocell input can detect a train in the reverse section and turn off power. A DCC command can then restore the power.

**Block Detection:** Either a photo cell or current can be used to detect a train in a block. The photocell can turn off the block. A DCC command can then restore the power.

**Over Voltage Protection:** If there is an over voltage on the track caused by a DCC System failure or other power inputs the PSX will shut down and protect decoders

**Wide Range of Current Trip Setting:** The currents can be adjusted over a range of 1.27 to 17.8 amps. Values can be set either with CV settings or Jumpers.

**Very Low Voltage Drop:** Breaker on resistance is less than 0.060 ohms, so the PSX has a low voltage drop even at high currents. Better than detectors that use a diode voltage drop.

**Manual or Automatic Reset:** Automatic reset of the breaker after 2 seconds. A switch can be used for a manual reset.

**Power On/Off by DCC:** Turn on/off output track power with your DCC Throttle!

**Outputs for LED Indicators:** LEDs can be added to monitor the input/output power and the status.

**System Reset:** CV63=42 sets all CVs to original factory values.

**Output for Audio Alert:** An audible sounder can be added to the card to alert if there is a short.

**Network Feed Back:** To Digitax Loco Net, NCE Cab Bus and Lens XpressNet for Shorted and Occupancy.

**No Power Supply Needed:** Board size: is 4.75 by 2.25 inches

**Flash Programmable:** Micro Processor can accept updated software if needed.

**Note: The PSX Circuit Bds are scribed and milled so you can separate into individual units if needed.**

**Note: The PSX-1 operates by opening one side of the two inputs leads when an overload is sensed. If you have a situation where both sides of the input line need to be opened on an overload, use the PSX-AR auto reverser instead of the PSX-1. The PSX-1 opens the path from J1-4 to J2-2 when the breaker senses an over load. Additional power to the PSX-2, 3, & 4 is connected by daisy chaining from J1, 1 and 2 to the next PSX J1, 3 and 4.**

*\*Instructions by Don Fiehmman*

## How do I Determine Power Districts?

There are really two types of power districts: those that are circuit-breaker protected zones on the layout and those that have their own independent Booster (also breaker protected). Probably the best way to determine where to place power districts is to take a look at the expected current draw, (Traffic), for each operating location on the layout. For example, a busy yard might have two switchers, one or more trains on the arrival and departure tracks, another train or two passing the yard on the main, and maybe a peddler working nearby local industries. If some or all of these trains have more than one locomotive, you could have 10 to 15 current-drawing units all competing for power in a fairly small area. Even assuming that the locomotives have efficient motors, this type of load may be heavy enough to slow down a DCC system running on a common 5A booster. Generally, our experience has shown that in HO if you have for a 12-14 awg buss and 20 awg feeders, that a 5 Amp system can support up to 10 operators. Many users overestimate the amount of Booster power needed. Try using the PSX Series first, then if your trains start to slow down you may need to add extra Booster to support the concentration of trains in this location. By dividing a layout into power districts in this manner, and using a combination of boosters and circuit breakers, you can make the most efficient use of available power on any mid-size or large-size layout.

# Special New Features for Revision K

## Manual Addendum for PSX Software Rev K and PSX-AR Manual Rev M

CV67=1 will inhibit the flashing of the Block Occupied output when CV50=1 AND the photocell is armed. Any other value of CV67 will allow the flashing IF CV50=1 AND the photocell is armed.

CV66 has three options: CV66=0 will always power up with the PSX output OFF. CV66=1 will always power up with the PSX output ON. CV66=2 will power up with the PSX output in the state it was in when the PSX was powered down. Note that for the purpose of saving the photocell calibration CV66 must either equal 0 OR the stored output state at power down must be OFF. If the stored power down state is ON, then when the PSX is powered up, the photocell WILL be calibrated. Hence, if the photocell is covered AND the power down state is ON, the photocell will mis-calibrate. In this case, an accessory command of OFF (NCE=2) to accessory address 2043 (default) will calibrate the photocell WITHOUT arming it. Of course, an accessory command of ON (NCE=1) will calibrate it AND arm it.

CV50 must equal 1 to enable photocell operation of the Block Detect output, to enable the photocell armed flashing (which can be inhibited by CV67), and to enable the storage of the photocell calibration when the PSX is powered down.

In all power up conditions, the status of the photocell will be disarmed.

### Determining the software revision of your PSX:

The software revision of the PSX is easily determined. Simply place the unit in the program mode and turn it on. D6 will flash the Morse code pattern of the software revision letter. The PSX breaker will flash long-short-long for revision K. The PSX-AR will flash long-short for revision N.

## Power Shield X-1, 2, 3, 4 Wiring:

Wire to the Power Shield should be heavy enough to carry the current. Size of wire depends on your scale. Too much resistance in the wire or rails can result in faulty short sensing. At a minimum, use 18 Awg for N, 14 Awg for HO and S, 12 Awg for O and G.

**Note: The small black screw terminals shown in picture are optional accessories available from your dealer. The large green input/output terminals come with units. Generally the small terminals are not needed as most of these are one time connections and are easily soldered to the bd. Use a small iron (20W-40W) for soldering to the bd.**

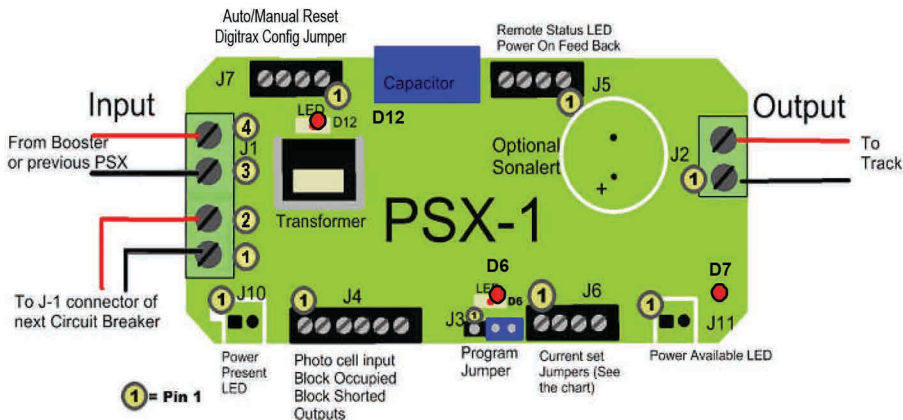

● Status LEDs ON: (D6: On, Shorted), (D7: Output-Power On), (D12: Input-Power On)

## Connector Description:

### J1 Input Power Connector

- J1-1 Connections for Daisy
- J1-2 Chaining to next PSX
- J1-3 DCC Input 2
- J1-4 **DCC Input 1**

### J2 Output Power Connector

- J2-1 DCC Output 2
- J2-2 **DCC Output 1**

### J3 Program Jumper

- J3-1 **Connection 1-2 for Programming**
- J3-2
- J3-3 **Connection 2-3 for Operations**

### J4 Block Occupancy

- J4-1 and J4-2 Photo Sensor Input
- J4-3 + Block Occupied Output (Network Feedback)
- J4-4 - Block Occupied Output (Network Feedback)
- J4-5 + Block Shorted Output (Network Feedback)
- J4-6 - Block Shorted Output (Network Feedback)

### J5 Status Outputs (Remote)

- J5-1 + status LED Remote (Output Shorted)
- J5-2 - status LED Remote (Output Shorted)
- J5-3 + Power ON (Network Feedback)
- J5-4 - Power ON (Network Feedback)

### J6 Trip Current Settings by Jumpers

J6-1-4 See Table to the right and also CV49 and Pg-7.

### J7 Auto/Manual Reset and Weak System Boost

- J7-1 to J7-2 Open: Auto Reset
- J7-1 to J7-2 Jumpered: Manual Reset (open to reset)
- J7-3 to J7-4 Exclusive Digitrax Config Jumper**  
Must be used for all Digitrax Systems. See Pg-3.

### J10 DCC Power In: Indicator (Remote)

- J10-1 + DCC Power In, LED Remote
- J10-2 - DCC Power In, LED Remote

### J11 Track Power On: Indicator (Remote)

- J11-1 + Track On LED Remote
- J11-2 -Track On LED Remote

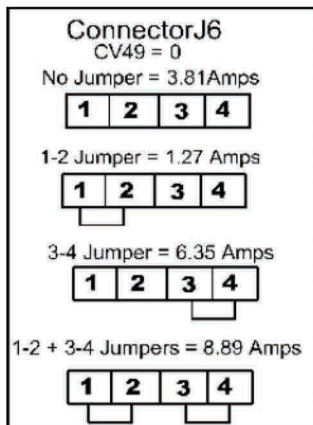
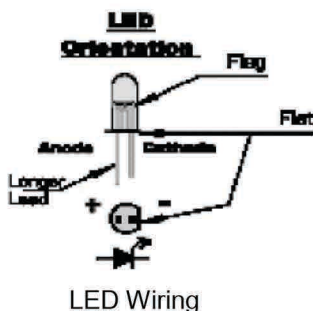

## Wiring Connections:

**J1** – DCC power input connections from the booster. It can be branched out to allow multiple connections to other breakers or reversers. The **Power Link** makes it easier to connect to another breaker or reverser. See the diagram on previous page.

**J2** –Circuit Breaker output to the track.

**J3** –Is the programming jumper. J3-2 to J3-3 is the normal operating configuration. J3-1 to J3-2, when connected with power on sets the breaker to enter the programming mode. See special instructions for Digitrax, Pg-5.

**J4-1** and **J4-2** are the inputs for the photocell detector used for the stopping function. Note: Be sure there is sufficient light above the cell to trigger the circuit. The photocell sensitivity is calibrated each time it is armed. Silonex, NSL-6112

**J4-3 (+)** and **J4-4 (-)** are open if the block is not occupied and are connected together (up to 5 mA) if the block is occupied. This is an opto-isolated output switch and provides no power.

**J4-5 (+)** and **J4-6 (-)** are connected together (up to 5 mA) when the breaker has detected a short circuit and open with no short. This is an opto-isolated output switch and provides no power.

**J5-1 (+)** and **J5-2 (-)** are for a remote status LED. The LED is connected directly to the terminals. No resistor is required. **Off** means normal– **Solid on** means a short circuit.

**J5-3** and **J5-4** are for network power status reporting.

**J6** – Sets the current trip level. When CV49=00 (default) the trip current is 3.81 amperes if no jumpers are installed. If J6-2 is connected to J6-1 and J6-4 to J6-3 is open, then the current trip is 1.27 amperes. If J6-4 is connected to J6-3 and J6-2 to J6-1 is open, then the current trip is 6.35 amperes. If J6-4 is connected to J6-3 and J6-2 is connected to J6-1, then the current trip is 8.89 amperes.

**J7-1** and **J7-2** are the auto/manual reset input. If the connections are open, the breaker will automatically try to reset every two seconds. If the terminals are connected together (like a SPST toggle switch or a N/C push button switch), then the breaker will remain off after a short until the connection from J7-1 to J7-2 is momentarily opened.

**J7-4 to J7-3 is the special exclusive Digitrax Config jumper and must be used by all Digitrax Systems!**

**J10-1 (+)** and **J10-2 (-)** are for a remote indicator showing DCC power is available to the breaker.

**J11-1 (+)** and **J1 1-2 (-)** are for a remote indicator showing that the track outputs are on (or off).

## Setting Addresses and Programming CV's: Optional/Not Required!

### Programming Steps:

The easiest way to program the PowerShieldX is on-the-bench. Connect pins J 1-4 and J 1-3 to the output of your DCC system. There is a small red LED on the Power Shield that will blink each time a command is accepted. There is also an LED near the power input and one near the power output used to indicate power status, After programming, return the program jumper back to the RUN position. If you make a mistake, don't worry, just go back and program the CV to the desired value. If you are hopelessly lost, set CV63 to 42 and you can start over again with factory default values.

## Setting **Addresses** and **Programming CV's** Cont'd:

**(1) Do Not Use Program Track!**

**(2) The PSX's addresses are SET by moving the program jumper as described below and issuing Accessory Commands ..like operating an accessory by using your DCC Throttle, see also, Pg-10**

System	Normal (Clear)	Thrown
Digitrax	c or Closed	t or Thrown
Lenz	+	-
MRC	ON	OFF
NCE	Normal/ON/ 1	Reverse/OFF/ 2

The Table above shows how the DCC Manufacturers identify the **Normal (Clear)** and/or the **Thrown** Route to operate accessories.

**(3) Configuration CV's are Programmed in Ops Mode, "on the main", also by moving the programming jumper, see Pg 7, use any non-loco address, except defaults, to initiate Ops Mode.**

**(4) It is important to remember that **Addresses are Set and CV's are Programmed!****

## Special Programming Instructions: Optional/Not Required!

Specific DCC Systems need to follow specific programming sequences to reliably program the **PSX's**, see Pg-12

**NCE and MRC:** Do not use the Accessory Programming Mode, only use Ops Mode for CV's see Pg-12

**Digitrax:** See also Pg-12

One of the main features of this software version is the function of the jumper from J7-3 to J7-4. The new software uses this connection as a Digitrax Configuration jumper. By installing this connection, all aspects of the PSX series are optimized to operate with Digitrax equipment. This includes the DCS50 and DCS51 as well as the DCS100, the DCS200 and the associated booster only units. As a result of these changes, it is recommended that ANY layout using Digitrax equipment should install this jumper.

When the jumper is installed, and the PSX is placed in the program mode, the default addresses of the PSX are automatically changed to 997 (on/off), 998 (photo cell arm), and 999 (switch control – PSX-AR only) to allow Digitrax systems to access these functions directly. If the PSX is reset (CV63=42), the default addresses will be 2042, 2043, and 2044 (which are NOT accessible to Digitrax equipment). Under this condition, it is necessary to remove power from the PSX (while still in the program mode) and then re-apply the power (in program mode with jumper in place) in order to program the Digitrax default addresses. Note that if the jumper is absent and the unit is placed in the program mode, the 997,998,999 sequence will be changed back to the normal default of 2042, 2043, and 2044. If the PSX has been programmed to an address other than one

of the two default address sequences, the presence or absence of the jumper will have no effect on the stored addresses. With the revised software and the Digitrax Configuration Jumper installed, it is no longer necessary to follow the “Special Digitrax Programming” instructions. The PSX will automatically prevent inappropriate programming of the unit’s addresses.

With the Digitrax Configuration Jumper installed, the PSX uses a different turn on algorithm that enhances the ability of Digitrax equipment to turn on multiple sound decoders without difficulty.

**Lenz:** See also Pg-12.

The Lenz system sends repeat accessory commands as long as you hold down the 1 or 4 command key. This ensures that the accessory decoder sees the message, but can result in the same address stored multiple times while programming the **PSX’s**. The solution is simple. Hold the 1 or 4 key down for only a short time. Once you see D10 flash indicating an address has been stored, release the control key. If you see multiple flashes, you have stored the same address more than once. Since the **PSX’s** will flash D10 each time you send it an accessory address, you can easily get a feel for the timing involved. In the normal operating mode (not programming mode), select an accessory address that has not been programmed into the **PSX’s**. Send an accessory command to this address and hold down the 1 or 4 control key. D10 will flash each time the command station repeats the accessory address. This will give you a feel of how long to hold the control key while you are programming multiple address.

## Setting Addresses and Programming CV’s: Optional/Not Required!

### There are Two (2) Accessory Addresses:

(1) The **First** accessory address lets you turn the output track power from the Power Shield on and off. (Default address 2042)

(2) The **Second** address is used to arm the photocell circuit. When the light level drops, due to a train covering the photocell, the power will turn off. Power can be turned back on (or off) under DCC control. The second address (2043 default) arms (when the command is “on”) the photo detector to turn the output **off** when the light level drops. This is designed to allow you to stop a train on a hidden staging track by arming the photo detector and then the reverser will turn off power to the section when the train covers the photo detector. Once the photo detector has tripped, it will not turn **off** track power until it is armed again with this accessory address command.

### (3) Setting the Two Accessory Addresses:

Addresses are set by moving jumper, J3 to positions 1-2 for the program mode with power **off**. Turn power **on** and the **next** accessory command issued by the DCC system will be stored as the **first address** (track on/off). By default, the unit will store the **next** address for the second address. Once the address is entered you can use either the on (clear or +) or the off (throw or -) function. Thus, you can have two sequential addresses starting at any desired address, or you can have two random addresses. Remember to power **off** and put the program jumper back to 2-3, unless you are going to program CV settings. Note: When changing from **run** to **program** mode, wait about 1 minute before turning power back on to the PSX.

## Reference Chart for the Two Accessory Commands

Function	Default Address	Your New
<b>Arm Output for Photo</b>	<b>2043</b>	?
<b>Track Power On/Off</b>	<b>2042</b>	?

## Programming CV's & Values: Optional

**Programming steps: Note: The Program Track is Not Used!**

The easiest way to program the Power Shield is on-the-bench Connect pins J1 -4 and J1 -3 to the output of you DCC system. There is a small red LED on the Power Shield that will blink each time a command is accepted. There is also an LED near the power input and one near the power output used to indicate power status. If you make a mistake, don't worry, just go back and program the CV to the desired value. If you are hopelessly lost, set CV63 to 42 and you can start over again with factory default values. Programming the CV values is done using the Programming-on-the-Main (POM) function. With power **off**, put the programming jumper on pins 1-2, then turn power back **on**. Then go into the Program-on-the-main mode. You will need to setup a "fake" loco address in order to get to the CV setting operation. Put in any address. (**Not** an address that is in use on the layout.) Hit enter, then you can start entering the CV numbers followed by the values. When done, turn power off and replace the program jumper to pins 2-3. See Sequential instructions Pg-10.

## CV Settings: Optional

### Timing Settings:

Note: there are no jumpers or CVs for setting time delays. The unit uses its own timing algorithm to figure out how to turn **on** a load. It differentiates between a short and a surge load, and operates accordingly. It will also recognize a difficult starting load and try to help the booster get it operating without tripping the booster's internal shutdown **CV49** – sets the current trip value. If CV49=0, then the Trip Current jumpers on J6 are enabled. Remember to use either the Jumpers or the CV settings, not both! The following trip currents can be set by programming:

CV49	Trip Current (Amps)	Continued	
00	3.81 or as Per Jumpers Chart >	CV	Trip Current
01	1.27	08	10.2
02	2.54	09	11.4
03	3.81	10	12.7
04	5.08	11	14.0
05	6.35	12	15.2
06	7.62	13	16.5
07	8.89	14	17.8
		15	19.1

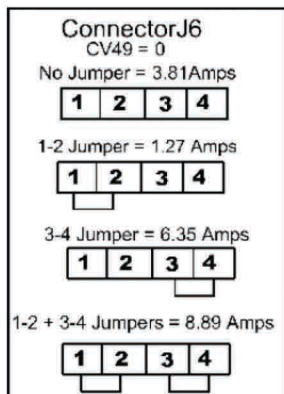



## Low Power Systems:

For the Digitrax Zephyr, 01 or 02 (maybe) are OK. The NCE Power Cab and Bachmann EZ should use value of 01.

Most 5amp boosters should be happy with 03 or 04. The default current is 3.81Amps

**Caution continuous operations at a value higher than CV49=08, (10.2 amps) without the addition of heat sinks to the output transistors may overheat or damage the PSX's!**

**Heat Sinks are generally not needed!**

**CV50** is the block detection source selection. CV50=0 selects block current as the parameter to activate the Block Occupied (J4-3 and J4-4) output. (See CV54.) CV50=1 will use the photocell to activate the Block Occupied output when the photocell is covered. Note that the photocell is self-calibrating and will adjust itself to the ambient light level at the time that the unit is turned on. If you need extra photocells, they are made by Silonex part number NSL-6112. The CV50 default is 0.

**CV51** is not used by the consumer.

**CV53** enables or disables the Weak System boost. CV53=0 disables the boost unless the Weak System Boost jumper is installed. Any other value enables the boost regardless of the presence or absence of a jumper on J7-3 and J7-4. The CV53 default is 0.

**CV54** sets current level at which the detector turns on to indicate the block is occupied. Values from 0 to 212. This allows you to set a level above the leakage current on track to minimize.

**CV55 –CV62** are not used at present time.

**CV63** allows control of the address programming point (same as on the Hare). **Setting a value of 42 to CV63 will cause the circuit breaker to set all CVs and addresses to factory defaults.** The CV63 default is 0.

**After setting the CVs turn power off and put the program jumper back to run position**

### Audible Short Indication

The two holes inside the circle on the top of the board are for use with an audible short indicating device. It is designed for use with a Digikey part 458-1005. The unit is installed with the (+) terminal in the square hole. See page 11.



## Mounting the PSX's

- (1) The PSX's can be mounted using # 4 screws. Spacers or non-metal washers can also be used to provide clearance. There are four possible mounting holes, one in each corner
- (2) The Screw Terminals are available from your dealer.
- (3) The Alarm is Digikey, 458-1005, also try your dealer.
- (4) One heat sink, not shown, Digikey 294-1085, may be needed, for each group of (2) output Transistors.

Also, we recommend Digikey, BER158, double-sided thermal tape (10" x 10" sheet, cut into strips) to attach the heat sink to the (2) large black output transistors. **Photocells not shown, Silonex part number NSL-6112. Heat Sinks are generally not needed!**

## User Guidelines:

When setting up gaps for power sections, we recommended that the gaps be staggered about 1/8". Perfectly aligned gaps may reduce the current needed for PSX's to reverse properly.

Power Shields are designed so all input/output connections are made to the screw terminals. Use up to 12 AWG wire. If you are using heavier buss wire, then solder a short length of 12 AWG wire to your heavier buss. If your Power Sections and Reverse blocks are greater than 10 Ft. long be sure to have at least 2 sets of track feeders for that section. Insufficient feeders will cause a voltage drop. If you are using both Power Shield X Breakers and Reversers on a layout, and the locomotives hesitate when crossing a reverse gap, then increase the Trip Current on the Power ShieldX Breakers to the next level or until the PSX-AR operates correctly. Test your PSX installation prior to running a train as follows.

Observe that your DCC booster is not shorted. Use a suitable metal object to short the track.

If you short the output simulating a track short, the status **LED D6** should come on and **D7** near the output should be off.

## Quick Start

- (A) All connections involve 2 Inputs from DCC Booster or the main-line buss and 2 Outputs to the isolated track block!
- (B) PSX 1,2,3,4 are ready to operate without programmable options!
- (C) Not compatible with Analog Address (00).
- (D) Test first before connecting to layout, see User Guidelines, Pg-8.

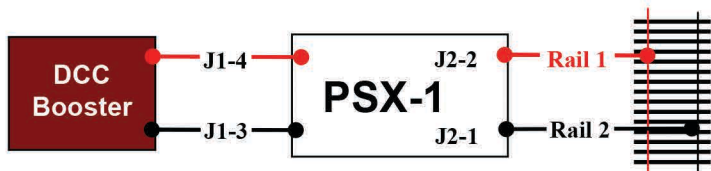

**Before wiring please check that the program jumper is on pins 2-3** of J3. (Pin 1 is nearest the center of the card.) See below.

Also when wiring more than one PSX for multiple power districts insure that all input/output polarities are the same. The illustration above shows the polarity and matching connector pin #'s. For **Common Rail** wiring the J2-1 output (Lower) is common and not needed. Both J1 inputs are still required.

Be sure to connect the two wires from the booster to the INPUT and the two wires to the track section to the OUTPUT connections. **If you connect the DCC Buss Power to the PSX's outputs you will damage the PSX!**

When power is applied the **red LED, D12** near the input and **D7** near the output should be **on**. If the status **LED D6** near the program jumper is **on** solid, you may have a short between the two wires from the output or in the track section. if you short the output simulating a track short, the status **LED D6** should come on and **D7** in the center of the card. See below.

**Before wiring please check that the program jumper is on pins 2-3** of J3. (Pin 1 is nearest  
Also when wiring more than one PSX for multiple power districts insure that all input/output polarities are the same. The illustration above shows the polarity and matching connector pin #'s. For **Common Rail** wiring the J2-1 output (Lower) is common and not needed. Both J1 inputs are still required.

Be sure to connect the two wires from the booster to the INPUT and the two wires to the track section to the OUTPUT connections. **If you connect the DCC Buss Power to the PSX's outputs you will damage the PSX!**

When power is applied the **red LED, D12** near the input and **D7** near the output should be **on**. If the status **LED D6** near the program jumper is **on** solid, you may have a short between the two wires from the output or in the track section. If you short the output simulating a track short, the status **LED D6** should come on and **D7** near the output should be off. See page **XXX** for more complete testing

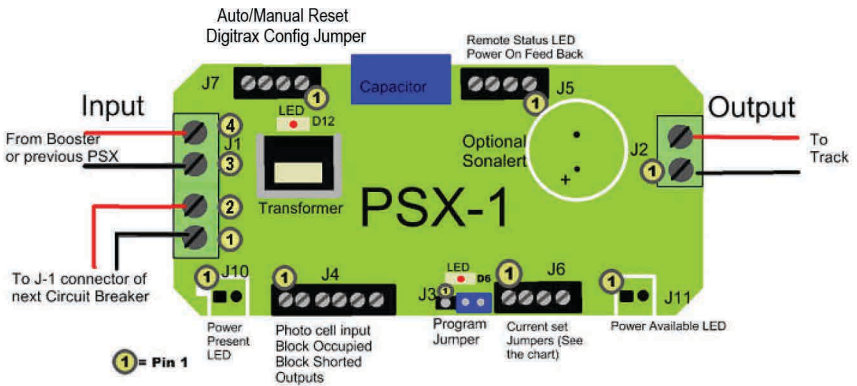

**Note:** The small black screw terminals shown in picture are optional accessories available from your dealer. The large green input/output terminals come with units. Generally the small terminals are not needed as most of these are one-time connections and are easily soldered to the bd. Use a small iron (20W-40W) for soldering to the bd.

## NCE: Using Pro Cab or Power Cab

### Setting PSX1's Addresses:

1. Turn DCC Power off.
  2. Move PSX-AR Jumper to Program Position.
  3. Turn DCC Power on.
  4. Press SELECT ACCY.
  5. Then use the keypad to enter the new switch number.
  6. Press ENTER then press either 1 or 2 to set the address.
  7. Repeat steps 4 thru 6 until all of the switch addresses are set.
  8. Turn DCC Power off.
  9. Move PSX-AR Jumper to Run Position.
  10. Turn DCC Power on.
- Test the switch setting using the SELECT ACCY key.

### Programming PSX1's CV's:

1. Turn DCC Power off.
  2. Move PSX-AR Jumper to Program Position.
  3. Turn DCC Power on.
  4. Use SELECT LOCO to address an unused locomotive number.
  5. Press PROG/ESC key to enter PROGRAM ON MAIN mode.
  6. Key ENTER to select any unused locomotive number, then ENTER again.
  7. Key 2 to enter PROG CV NUM.
  8. Enter CV number then ENTER.
  9. Enter value to be stored then ENTER.
  10. Repeat steps 8 and 9 until finished.
  11. Press PROG/ESC to return to normal operation.
  12. Turn power off, put the PSX-AR Program Jumper into the Run position.
  13. Turn power on.
- Test the PSX-AR using the SELECT ACCY key.

## MRC: Using the Prodigy Advance Cab:

### Setting PSX1's Addresses:

1. Turn DCC Power off.
  2. Move PSX-AR Jumper to Program Position.
  3. Turn DCC Power on.
  4. Press ACCY key.
  5. Then use the keypad to enter the new switch number.
  6. Press ENTER then press either 1 or 2 to set the address.
  7. Repeat steps 4 thru 6 until all of the CV value are set.
  8. Turn DCC Power off.
  9. Move PSX-AR Jumper to Run Position.
  10. Turn DCC Power on.
- Test the switch setting using the ACCY key.

### Programming PSX1's CV's:

1. Turn DCC Power off.
  2. Move PSX-AR Jumper to Program Position.
  3. Turn DCC Power on.
  4. Press LOCO to address a key in an unused locomotive number.
  5. Press PROG key to enter PROG MAIN TRACK mode, then press ENTER.
  6. Continue to press ENTER until CV# is in the display.
  7. Enter the CV number then ENTER.
  8. Enter the value to be stored in the CV then ENTER.
  9. Repeat steps 8 and 9 until finished.
  10. Press ENTER to return to normal operation.
  11. Turn power off and put the PSX-AR Program Jumper into the Run position.
  12. Turn DCC power on.
- Test the PSX-AR using the ACCY key.

## Digitrax: Using the DT-400/402

### Setting PSX Addresses:

1. Disconnect PSX from DCC power
  2. Move PSX Jumper to Program Position
  3. Turn DCC power on "PWR" + "Y+"
  4. After 30 seconds, reconnect DCC power Program CV's at this time (see below)
- First, In CV 63, enter a value of 42 to reset. Then set any other CV's needed. Do not Move Programming jumper or turn off power. Exit program mode and go to step 5.
5. Press "SWCH" key to enter Switch Mode
  6. Select the switch number to be set using the keypad or RH knob.
  7. Press either the "OPTN" or "CLOC" key to set address.
  8. Repeat steps 6 and 7 until all addresses set.
  9. Press "EXIT" key to return to LOCO mode.
  10. Turn DCC power off "PWR" + "N-".
  11. Move PSX Jumper to Run Position
  12. Turn track power on. Test the switch address setting by using the "SWCH" key + switch addresses.
  13. Turn power off and put the program jumper into the Run position.
  14. Turn DCC power on. Test the PSX using the switch commands.

### Programming PSX CV's: Do Setting Addresses First, See Above

1. Disconnect PSX from DCC power.
2. Move PSX Jumper to Program Position
3. Turn DCC power on "PWR" + "Y+"
4. After a few seconds, connect DCC power to the PSX
5. Select an unused locomotive number with the keypad or RH knob.
6. Press "PROG" key until you get from Pg to Po
7. Use LH throttle to set, dial the CV # and the RH throttle for the CV value.
8. Press, "ENTER"
9. Repeat steps 7 & 8 until all the CV values are set.
10. Press "EXIT"

## Lenz: Using the LH100:

### Setting PSX1's Addresses:

1. Turn DCC power off.
2. Move PSX-AR Jumper to Program Position
3. Turn DCC power on
4. Press "F5" key to select "SW" mode.
5. Enter the switch number to be set using the keypad, then press ENTER.
6. Press either the "+" or "-" key to set the address. Let LED blink once.
7. To enter another address press the "CI" key.
8. Repeat steps 5-7 until all addresses are set.
9. Press "ESC" key to return to normal.
10. Turn DCC power off.
11. Move PSX-AR Jumper to Run Position
12. Turn track power on.
13. Test the switch address setting using "SW" mode and the new switch address(es).

### Programming PSX1's CV's:

1. Turn DCC power off.
2. Move PSX-AR Jumper to Program Position
3. Turn DCC power on.
4. Select a locomotive number with the keypad that is unused on your layout.
5. Press the "F" keys and the "+" or "-" key to select "POM" mode then hit "Enter".
6. Press "+" or "-" until "CV" is displayed then press "Enter".
7. Key in the desired CV number then press "Enter"
8. Enter the CV value to change, then press "Enter".
9. The display will show the CV number and value to be programmed.
10. Hit "Enter" to program the CV, note the LED on the PSX-AR flashes when the key is released
11. Press "Esc" key to return to Step 7) or press  $\text{ESC}$  three times to exit CV programming
12. Turn power off and put the Program jumper into the Run position